



Sewing machine Division of Fujioka Newlong Industrial Co., Ltd. factory was granted ISO9001 Certifications on October 18, 1999.

PORTABLE BAG CLOSER

NP-3II NP-7A



NP-3II

Recommended for bags of all materials, like jute, paper, cotton, PP, etc.
Double thread chain stitch ensures tightest closure.



Now supplied with more powerful 90 Watt motor on Standard Models

NP-7A

For minimum cost closing of all kinds of Bags. Single thread chain stitch, with simple mechanism for easier maintenance. New type NP-7A is provided with a plastic handle and an auto-lubrication.

NEWLONG INDUSTRIAL FZC

NP-3II

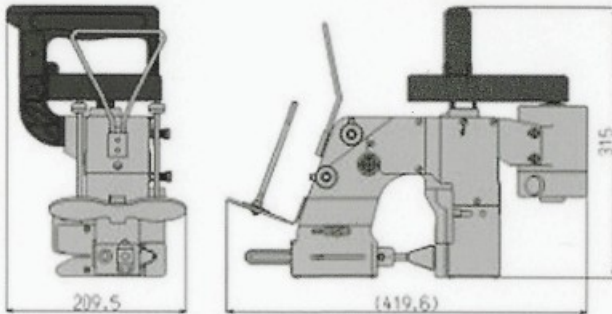

SPECIFICATIONS – NP-3(II) Portable Bag Closer

Capacity (r.p.m)	1,650 ± 100
Stitch Range (mm)	8.5 (fixed)
Seam	Double Thread Chain Stitch
Thread Cutting	Integrated, Mechanical
Drive Motor (w)	90,1 Ph (specify voltage)
Net Weight (kg)	7 kgs with thread
Gross Weight (kg)	Approx. 9
Measurement (cff)	Approx. 2.5

NP-7A

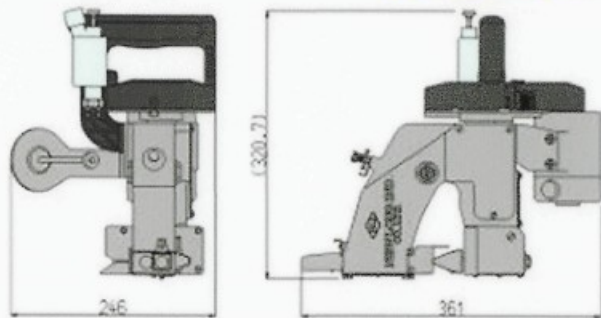

SPECIFICATIONS – NP-7A Portable Bag Closer

Capacity (r.p.m)	1,700 ~ 1,900
Stitch Range (mm)	8.5 (fixed)
Seam	Single Thread Chain Stitch
Thread Cutting	Integrated, Mechanical
Drive Motor (w)	90,1 Ph (specify voltage)
Net Weight (kg)	6 kgs with thread
Gross Weight (kg)	Approx. 8
Measurement (cff)	Approx. 2.5

MADE IN JAPAN



NEWLONG INDUSTRIAL CO., LTD.

8-14, Shiratori 4-chome, Katsushika-ku, Tokyo 125-0063, Japan



NEWLONG INDUSTRIAL FZC

Sharjah Airport International Free Zone (SAIF-Zone), P.O. Box 120127, Sharjah, United Arab Emirates
 Tel: +971 6 5573680 Fax: +971 6 5573681 email: info@nli-fzc.com website: www.nli-fzc.com

© Specifications are subject to change without prior notice. Unauthorised reproduction/alteration is strictly prohibited

© 2006 NEWLONG INDUSTRIAL CO., LTD.

CTG NO. MK-003

FZ06BSBC01 03 2006